

嵌入式焗爐 OVEN

FV-EL61/63



賢く優しいオープンで、
安心調理と簡単お掃除。



智能. 易於打理. 安全 Intelligent. Easy-Care. Secure.

具10種智慧功能設計，輕易使用及有三款多功能配件，可讓您在廚房舒適地烹調及品嚐各種美食。機內搪瓷爐腔可防止油脂和污垢積聚，更易清潔和保養。

加上三層玻璃門和兒童安全鎖等附加安全功能，為您和您的孩子準備食物時既輕鬆又安全。

Designed with 10 Additional intelligent, user-friendly features and three multi-functional accessories, this range of ovens enable you to serve variety of cuisine from your cozy kitchen. The enamel lining surfaces prevent grease and dirt accumulation, making it easier to clean and maintain.

With additional safety functions such as tripled-layered glass and child safety lock, food preparation for you and your children is effortless and safe.



進階功能 ADVANCED FUNCTIONS

01/ 簡單快捷#
Quick & Easy



五個食物準備程序，可輕鬆製作出30種不同菜式
Five food preparation programs for easy access to 30 different menus

02/ 烤架延伸軌道#
Telescopic Rails



兩組烤架延伸軌道，更加安全可靠
Two sets of fully extendable telescopic rails keep gilding of accessory secured and safe

03/ 機內搪瓷爐腔
Enamel Coated Cavity



機內無縫設計和搪瓷爐腔，加上大容量內腔，易於清潔和保養
Seamless enamel coated, extra large cavity ease cleaning and maintenance

#只限於FV-EL63 Available only in FV-EL63

顏色 COLORS



FV-EL61



FV-EL63

產品圖像僅用於說明，可能與實際產品有所不同。
Product images are for illustrative purposes only and may differ from the actual product.

安裝 INSTALLATIONS

FV-EL61

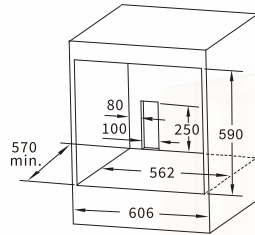
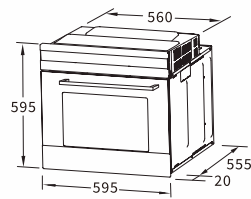

FV-EL63

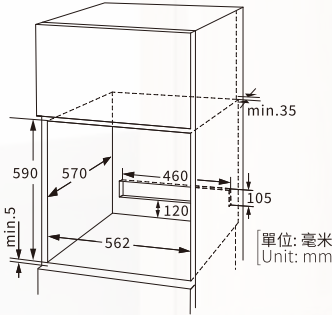
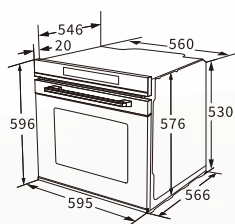

配件 ACCESSORIES



食物探針
Meat Probe
(EL63)



金屬架
Wire Rack

搪瓷塗層烘焗盤
Enamel Baking Tray

高深搪瓷塗層烘焗盤
Deep Enamel Baking Tray

規格 SPECIFICATIONS

型號名稱	Model Name	FV-EL61	FV-EL63
類型	Type	嵌入式焗爐 Built-in Electric Oven	嵌入式焗爐 Built-in Electric Oven
總尺寸[毫米]	Gross Dimensions [mm]	W595 x D575 x H595	W595 x D566 x H595
開孔尺寸[毫米]	Cut-out Dimension [mm]	W562 x D570 x H590	W562 x D570 x H590
重量[千克]	Weight [kg]	31.5	31.5
電壓[V / Hz]	Voltage [V/Hz]	220V 50Hz	220V 50Hz
額定功率[瓦特]	Rated Power Consumption [watts]	3000 15A獨立插座 15A single phase connection	2900 15A獨立插座 15A single phase connection
可調節溫度	Temperature Range	50-250°C	30-250°C
玻璃門層數	No. of Layers of Glass Door	3	3
顯示	Display	LED 顯示	彩色顯示 Color Display
開關	Switch	兩個按鈕+輕觸式 2 Knobs+Touch Control	輕觸式 Touch Control
機內	Cavity	搪瓷爐腔 Enamel Coating	搪瓷爐腔 Enamel Coating
層架的側面滑槽	No. of Rack Position	5	5
功能	Function	8	17
機內容量[升]	Cavity Capacity [L]	70	72
計時器	Timer	✓	✓
兒童安全鎖	Child Safety Lock	✓	✓

配件	Accessories
	- 金屬架
	- 搪瓷塗層烘焗盤
	- 高深搪瓷塗層烘焗盤
	- Wire Rack
	- Enamel Baking Tray
	- Deep Enamel Baking Tray

	- 金屬架
	- 搪瓷塗層烘焗盤
	- 高深搪瓷塗層烘焗盤
	- 食物探針
	- 烤架延伸軌道(2套)
	- Wire Rack
	- Enamel Baking Tray
	- Deep Enamel Baking Tray
	- Meat Probe
	- Telescopic Rail (2 sets)

功能 FUNCTIONS

FV-EL61

- 解凍** 用於溫和地解凍冰凍食品。
DEFROST For gently defrosting frozen food.
- 底部加熱** 可保持食物溫暖。
BOTTOM For keeping food warm.
- 傳統加熱功能** 適用於傳統的烘烤和燒烤效果。特別適合濕潤的蛋糕。
CONVENTIONAL For traditional baking and roasting on one level. Especially suitable for cakes with moist toppings.
- 傳統加熱功能+風扇** 烹調食物，令其外脆內軟。適用於燒烤和烤焗大塊肉類。
CONVENTIONAL + FAN For browning dishes lightly on the outside while keeping the moist in the inside. Suitable for grilling and roasting big pieces of meat.
- 發熱器** 用於燒烤份量較少的食物，使食物表面或外皮酥脆。
RADIANT HEAT For grilling small amounts of food and for browning food.
- 雙重烤制** 用於燒烤扁平食物，使食物表面或外皮酥脆。
DOUBLE GRILL For grilling flat items and for browning food.
- 雙重烤制+風扇** 用於燒烤扁平食物和焦化食物。風扇將熱量均勻分佈在焗爐內。
DOUBLE GRILL + FAN For grilling flat items and for browning food. The fan distributes the heat evenly around the cavity.
- 環保** 節約能源。
ECO For energy saving.

FV-EL63

- 解凍** 用於溫和地解凍冰凍食品。
DEFROST For gently defrosting frozen food.
- 底部加熱** 令披薩、餡餅和糕點底部酥脆。加熱來自底部加熱器。
BOTTOM For adding extra browning to the bases of pizzas, pies, and pastries. Heating comes from the bottom heater.
- 傳統加熱功能** 適用於傳統的烘烤和燒烤效果。特別適合濕潤的蛋糕。
CONVENTIONAL For traditional baking and roasting on one level. Especially suitable for cakes with moist toppings.
- 傳統加熱功能+風扇** 用於在一個或多個層架上進行烘烤。風扇將來自加熱元件的熱量均勻地分佈在焗爐內。
CONVENTIONAL + FAN For baking and roasting on one or more levels. The fan distributes the heat from the heating elements evenly around the cavity.
- 發熱器** 用於燒烤份量較少的食物，使食物表面或外皮酥脆。
RADIANT HEAT For grilling small amounts of food and for browning food.
- 雙重烤制** 用於燒烤扁平食物，使食物表面或外皮酥脆。
DOUBLE GRILL For grilling flat items and for browning food.
- 雙重烤制+風扇** 用於燒烤扁平食物令表面或外皮酥脆。風扇將熱量均勻分佈在焗爐內。
DOUBLE GRILL + FAN For grilling flat items and for browning food. The fan distributes the heat evenly around the cavity.
- 環保** 節約能源。
ECO For energy saving.
- 一般加熱** 烘烤於一層或多層食物。環形加熱風扇令熱力均勻圍繞爐腔。
CONVECTION For baking and roasting on one or more levels. Heat comes from the ring heater surrounding the fan evenly.
- 比薩** 比薩類食物底部需要大量熱力。熱力來自底部和環形加熱器。
PIZZA For pizza and dishes which need a lot of heat from underneath. Heat comes from the bottom heater and the ring heater.
- 慢煮** 用於烹飪嫩滑多汁的肉類。以低溫模式使熱力由上至下加熱。
SLOW COOKING For cooking tender and juicy meat. Heat comes from top and bottom at low temperature.
- 烘乾** 用於乾燥小片的水果、蔬菜和香草。
DRYING For drying small slices of fruits, vegetables and thin herbs.
- 保持溫度** 為煮好的食物保溫。
KEEP WARM For keeping the cooked food warm.
- 預熱餐具** 把餐碟加熱。
PLATE WARM For warming the plate.
- 麵團發酵** 用於發酵酵母、麵團和發酵麵糰以及乳酪。
DOUGH PROVING For proving yeast, dough and sourdough and culturing yogurt.
- 安息日模式** 使用安息日模式，您可以將烹飪過程設置為72個小時，無需開關的情況下保持食物溫暖。
SABBATH MODE With the Sabbath mode, you can set the cooking process for 72 hours, to keep food warm without switching on and off the oven.
- 食物探針** 探測肉類溫度，用於厚度的肉類，如牛排和雞肉。
MEAT PROBE For checking meat like steak and chicken.

